

 **next desk**[™] Solo Plus



Assembly Instructions

Preface

We are delighted that you have chosen NextDesk. Congratulations, you have selected the most advanced and sophisticated power-adjustable workstation available today. Our bodies weren't meant to sit or stand for hours at a time. Now you have the choice to sit or stand with the press of a button.

This user manual gives basic instructions for NextDesk Solo Plus model. We are sure that your NextDesk will provide you with many years of enjoyment. Should you ever experience a problem with any our products, please contact us.

Thank you for choosing Nextdesk. We hope you enjoy your NextDesk for many years!

~NextDesk Team



Table of Contents

Safety Instructions.....	Page 1
Unpacking, Preparation, Tools Needed.....	Page 3
System Components List & Parts List.....	Page 4
Components Diagram.....	Page 5
Step 1 : Connecting Lifting Columns to Desktop.....	Page 6
Step 2 : Connecting Floor Supports to Columns.....	Page 7
Step 3 : Connecting Cables.....	Page 8
Step 4 : Initializing Desk.....	Page 9
Step 5 : Cable Management.....	Page 10
Operating Controller.....	Page 11
Anti-Collision Feature.....	Page 12
Maintenance & Description.....	Page 13
Troubleshooting & Repair.....	Page 14
Warranty Information.....	Page 15





SAFETY INSTRUCTIONS

WARNING! FAILURE TO COMPLY WITH OR OBSERVE ALL ASSEMBLY SAFETY AND OPERATING INSTRUCTIONS AND WARNING REGARDING THE USE OF THIS PRODUCT MAY RESULT IN SERIOUS BODILY INJURY.

The safety of NextDesk clients and users is our primary concern. To ensure safe operation:



Read and understand this manual before attempting to install or operate the NextDesk



Verify that everyone who uses the NextDesk is informed of the contents of this manual. This is the responsibility of the purchaser.



Leave this manual near the NextDesk and if possible, permanently affixed to the desk.

Safe use of the system is possible only when the operating instructions are read completely and the instructions contained are strictly observed.

Failure to comply with instructions marked with the "NOTE" symbol may result in serious damage to the system or one of its components. Persons who do not have the necessary experience or knowledge of the NextDesk must not use the product. Persons with reduced physical or mental abilities must not use the NextDesk, unless they are under supervision or they have been thoroughly instructed in the use of the apparatus by a person who is responsible for the safety of these persons.



QUICK TIP: IS YOUR FLOOR UNLEVEL?

NextDesk is intended for use on level floors. If you determine that your floor is unlevel, you may wish to order floor supports with leveling screw pads.





SAFETY INSTRUCTIONS (cont.)

Children must remain under close supervision to ensure that they do not play with the product.



It is important for everyone who is installing or using the NextDesk to have the necessary information and access to this User Manual.



If there is visible damage on the product it must not be installed.



The NextDesk is not intended for use by young children or for those persons who require supervision.



Children should be supervised to ensure that they do not tamper or play with the NextDesk.

Before Installation, Reinstallation, or Troubleshooting:



Stop the NextDesk.



Switch the power supply and pull out the main power supply plug.



Relieve the NextDesk of any loads, which may be released when unexpected.

Before Start-up:



Make sure the NextDesk has been installed as specified in this manual.



System Connection - the individual parts must be connected before the control box is connected to the main power supply.



If the control box makes unusual noises or has an odor, switch off the main power supply immediately.



Make sure the cables are not damaged.

UNPACKING:

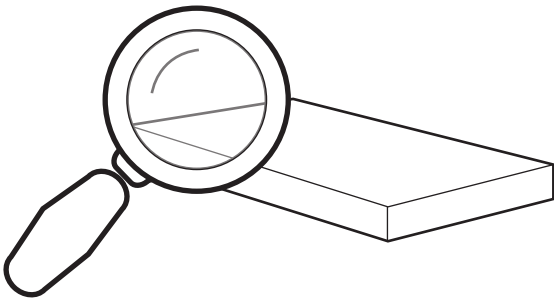

Carefully remove the packaging from the NextDesk and then inspect all components for any shipping damage. Report any damage to the shipping company and fill out a concealed damage report.

PREPARATION:

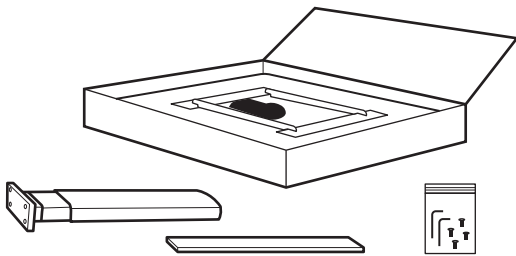

It is recommended to leave desktop in the original box for steps 1-6 to preserve the desktop finish. Remove all other parts from the box.



QUICK TIP: INSTALLING SCREWS

DO NOT over tighten screws during installation







SYSTEM COMPONENTS LIST

- 1 - Desktop (control box, cable, controller, mounting plate, any accessories attached)
- 1 - Lifting Column
- 1 - Bottom Support Footing
- 1 - 10' AC Chord



PARTS LIST

-  4 - M6 - 25mm Machine Screw (Long)
-  6 - Lift Mounting Screws 10mm (Short)
-  1 - Allen Wrench / Hex Key (5/32)
-  1 - Allen Wrench / Hex Key (1/8)
-  5 - Adhesive Zip Ties





COMPONENTS DIAGRAM

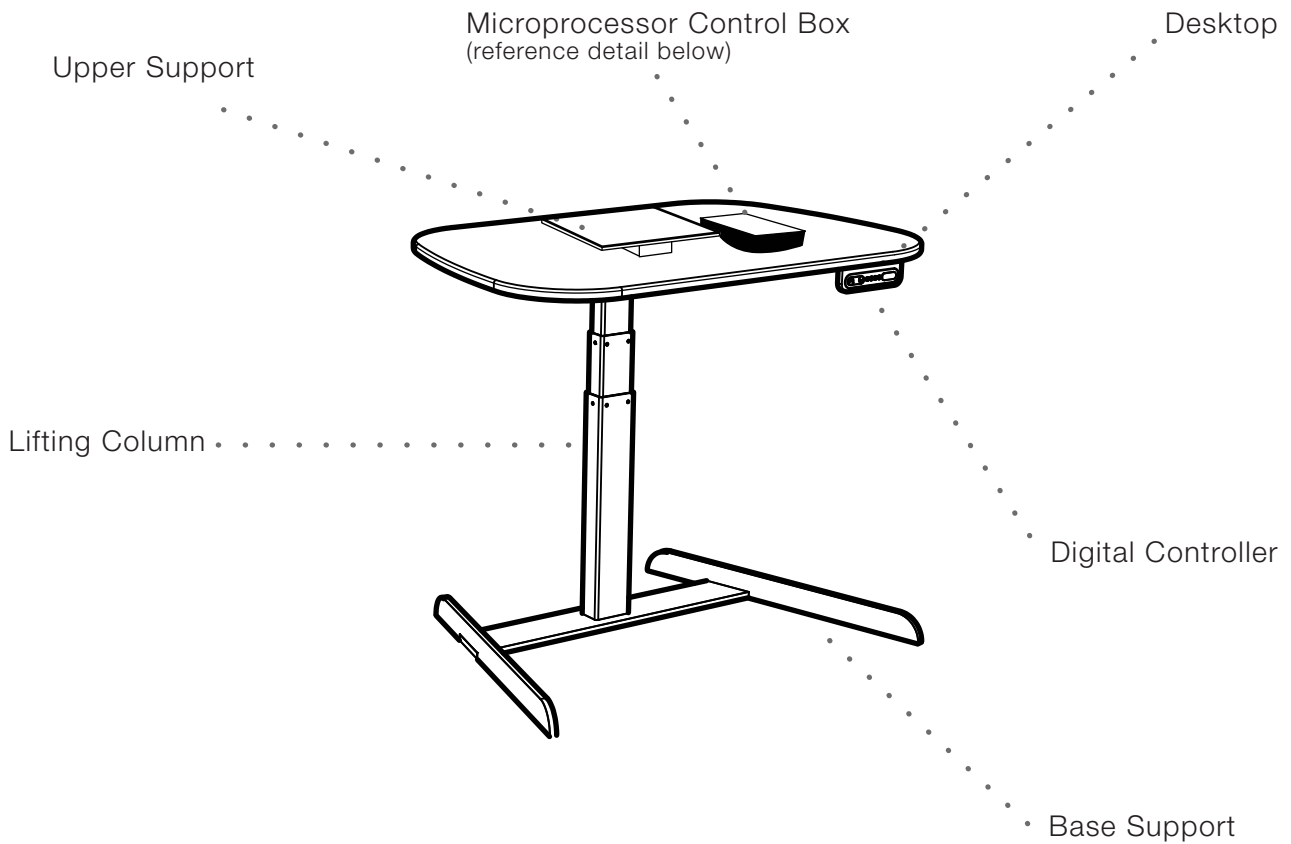

Microprocessor Control Box

(Top View)

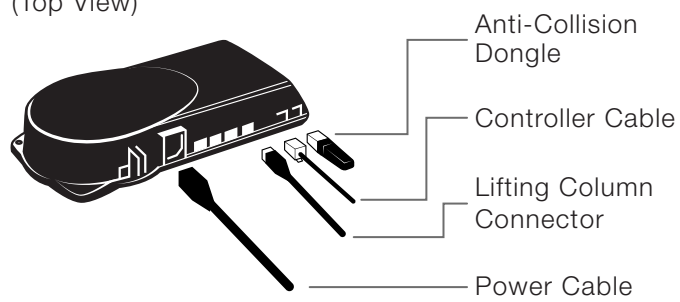

Step
1

CONNECT LIFTING COLUMN TO DESKTOP



Hardware Required
6x - 10mm Allen Screws

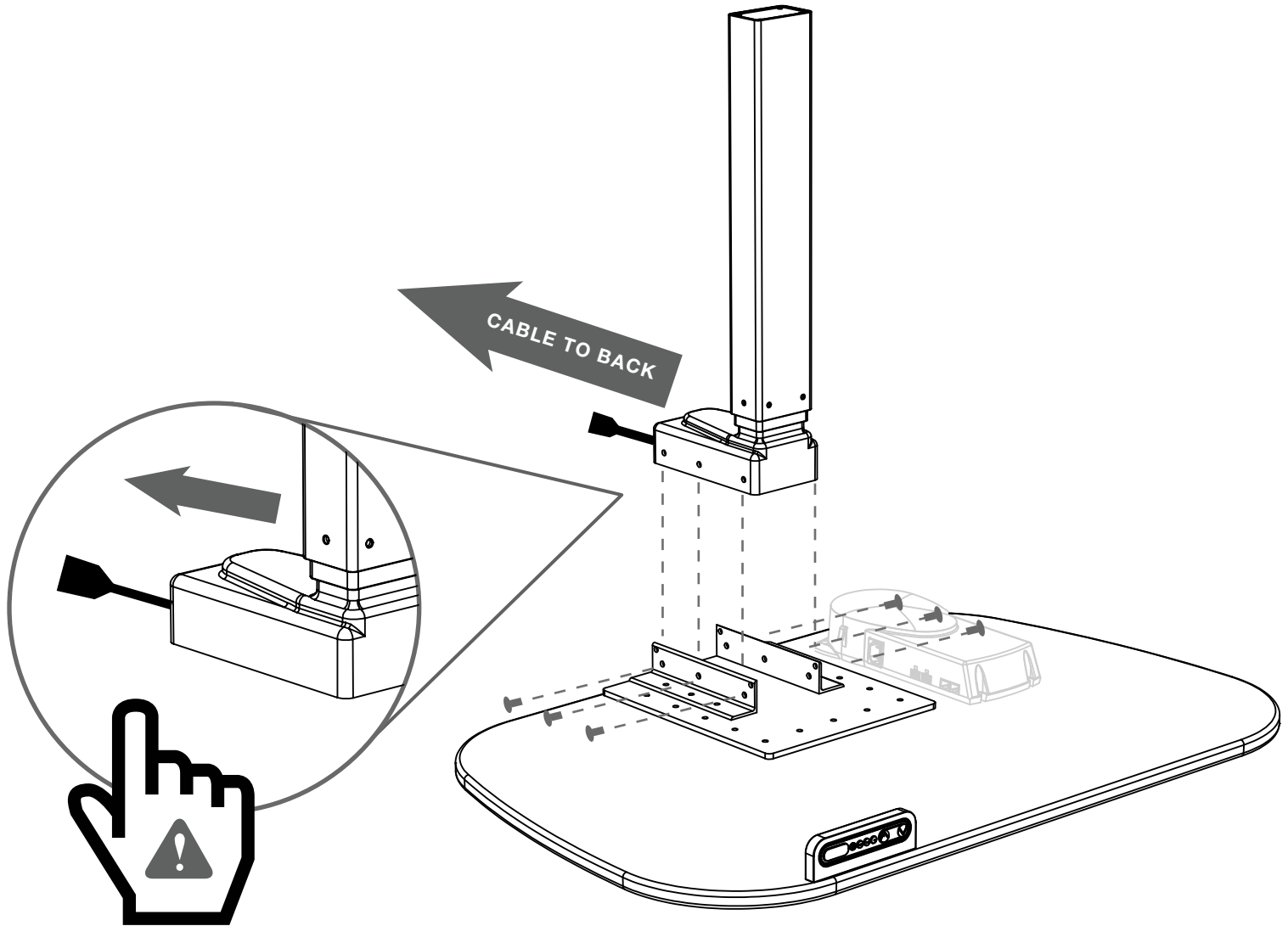

IMPORTANT:

Cable must face back of desk



Step
2

CONNECT FLOOR SUPPORT TO COLUMN

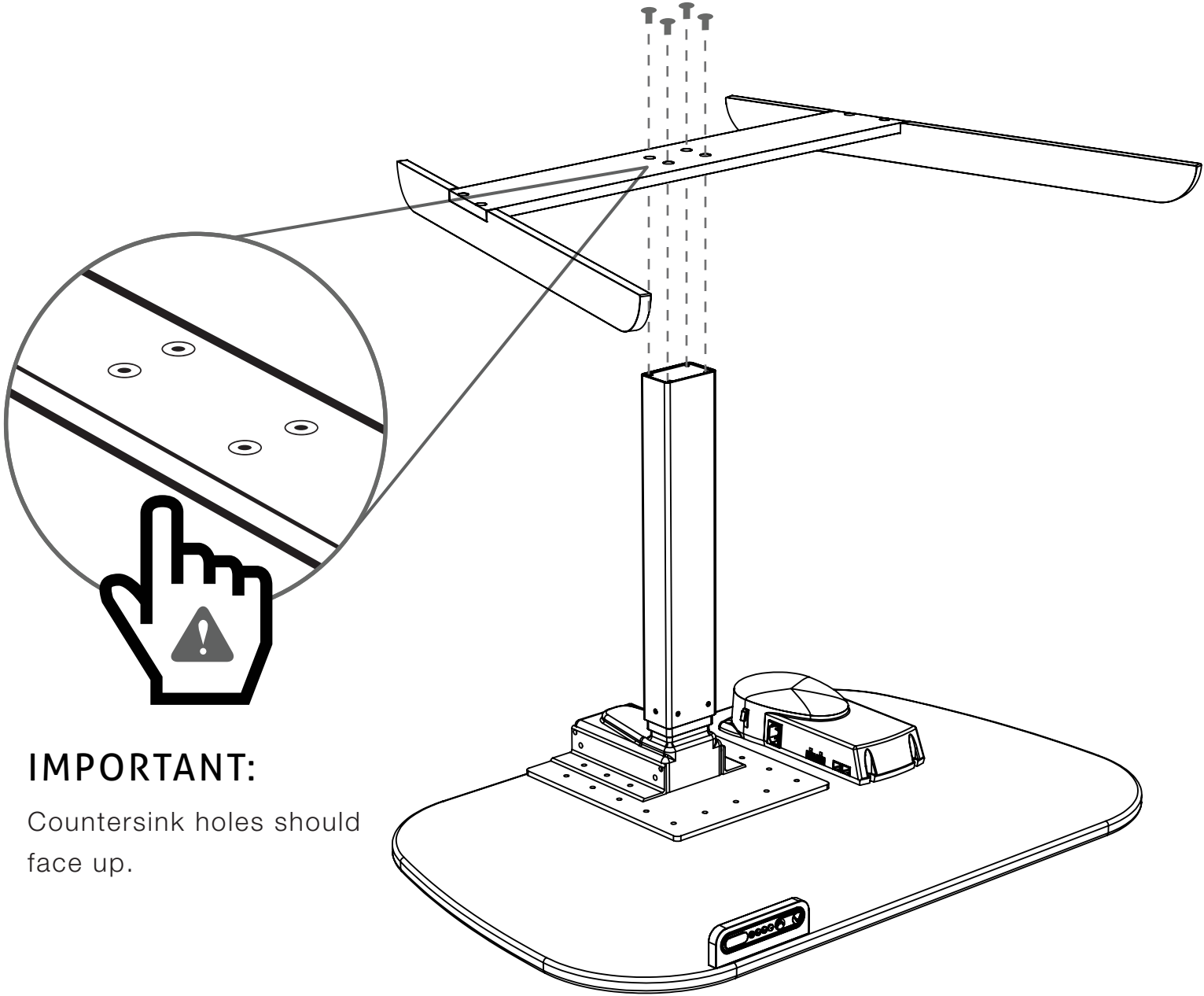

IMPORTANT:

Countersink holes should face up.



Step
3

CONNECT CABLES

Motor cables are pre-mounted to desktop and pre-wired to the control box. Plug each motor cable into the cable leading to the control box.

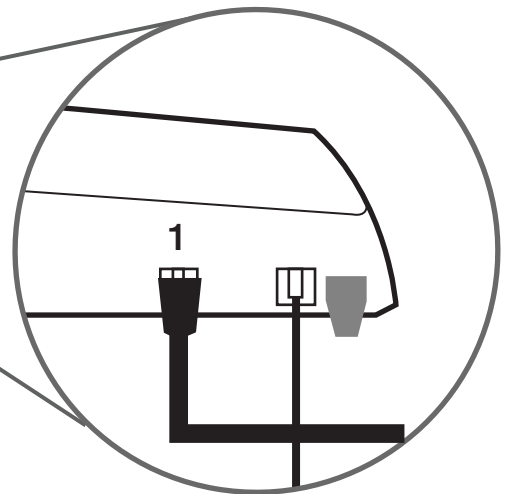
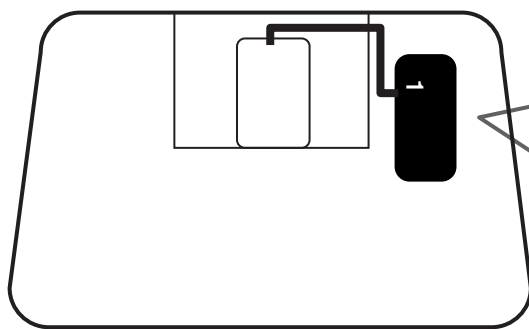
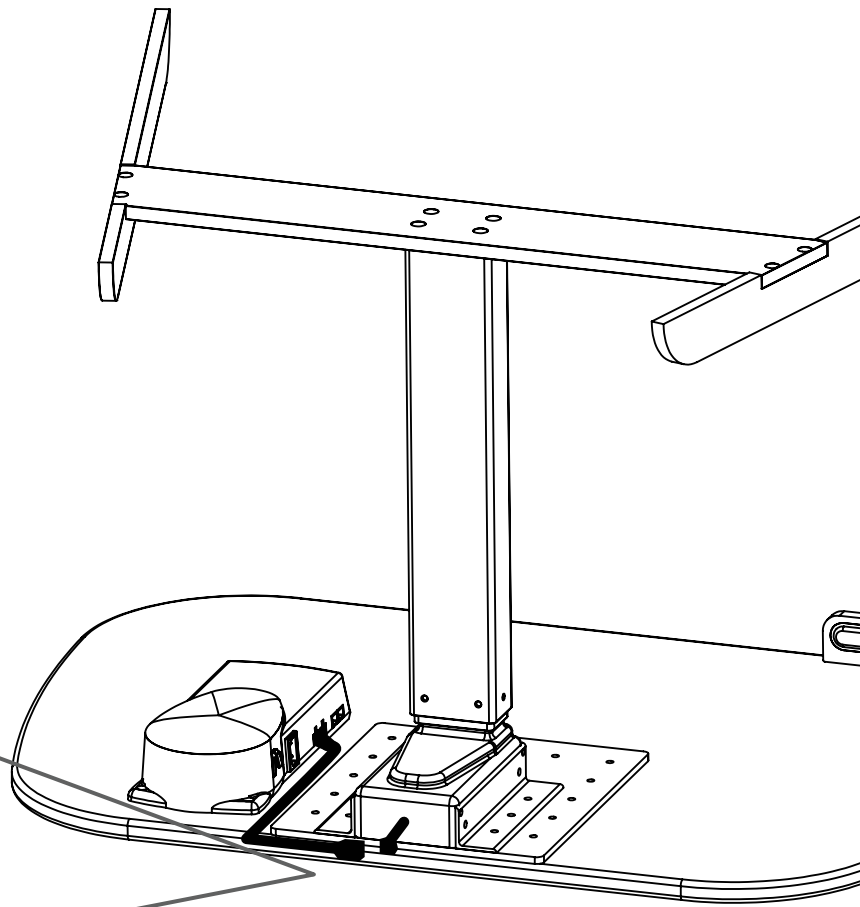
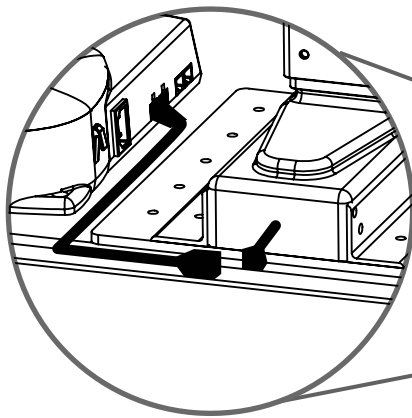

IMPORTANT:

DO NOT plug desk into power outlet at this time.



Step
4

INITIALIZE DESK



IMPORTANT:

Carefully turn desk upright on level floor.

Desk is **NOT** complete.

DO NOT put weight or load on desk.

Use proper lifting techniques when lifting. Failure to do so could result in serious back injury.

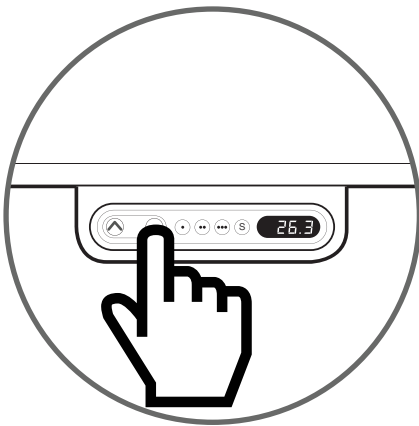
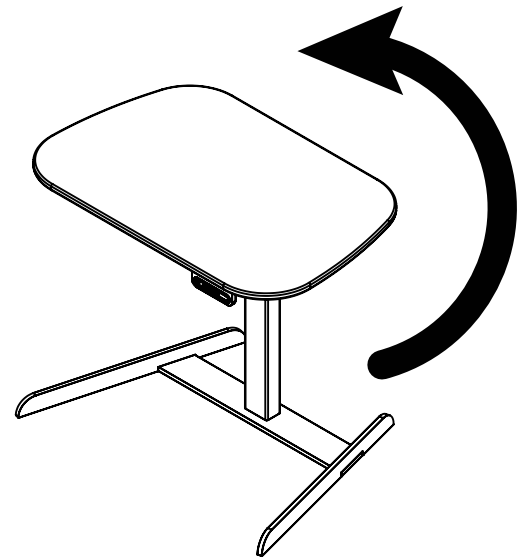

A. Connect power cord to standard wall outlet. For desks with Power Management, the power cord is factory attached. For desks without Power Management, plug power cord into the control box prior to connecting to wall outlet.

B. Press and hold the (✓) button until the lifting columns have completely retracted and continue to hold for 5 seconds after all movement stops.

C. Once the columns are completely retracted, they will automatically run approximately 5 mm out again and then slowly run in again. Do not release the (✓) button until 5 seconds after all movement has completely stopped.

Note: It is sometimes necessary to press the (✓) button twice to start initialization. There may be a short delay before movement begins.

Note: If the (✓) button is released before the sequence is complete then initialization is interrupted and the process must be started again from the beginning.



Step
5

CABLE MANAGEMENT

Maintain the sleek lines of NextDesk. Spend a few minutes to tidy up all visible cords and cables and then cover with NextFlex.

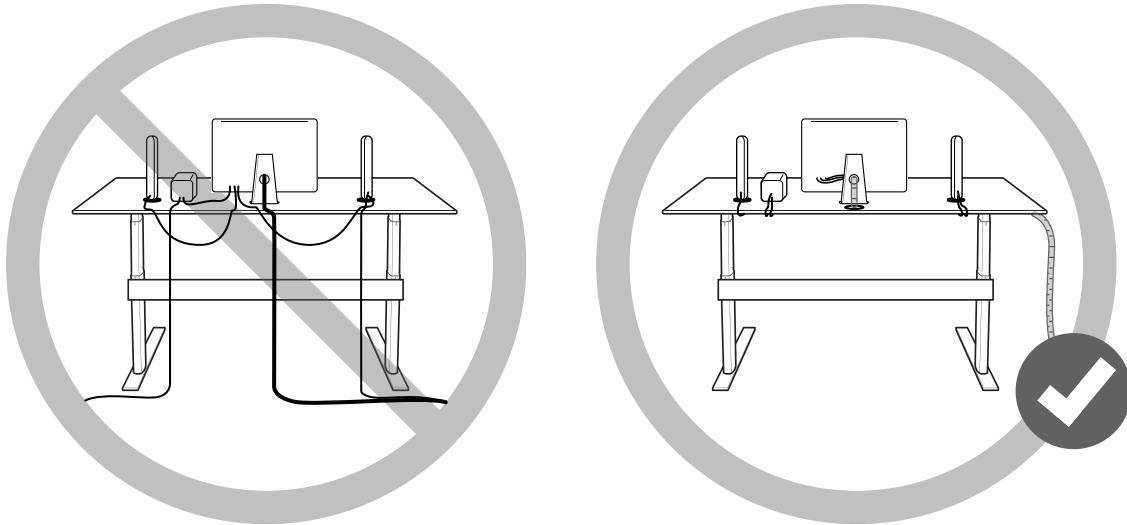

- Straighten and untangle cables. Connect loose cables into a bundle
- Group the main cables running to your desk into a bundle (main power cable/network cable/printer cable)
- Group the cables between your PC and desktop into a bundle (monitor/speakers)
- Cover bundles with NextFlex expandable cable cover
- Attach the self-adhesive zip ties underneath NextDesk and secure cables and bundles
- Consider the optional NextDesk Vanity Cover/Cable Raceway for even easier cable management (available in matching aluminum)



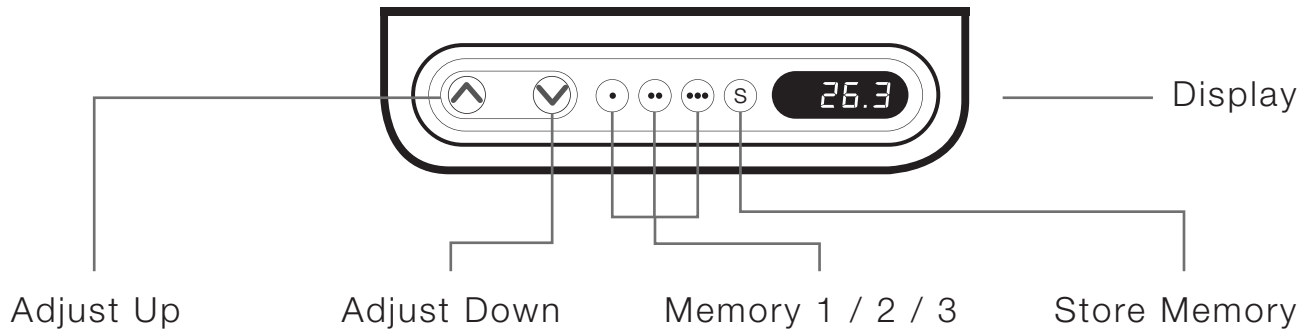

Up and Down (▲ ▼)

Press either the up or down button for parallel drive and the system will drive until the button is released again or the system reaches end position.

Programmable Memory

The four small buttons are used for memory drive/storing memory.

Store Memory Presets

- a. Raise or lower the desk to the height you wish to store as a preset.
- b. Press and release the (S) button.
- c. Within these two seconds, press a memory button (● or ●● or ●●●).
The panel will acknowledge by showing "1 ", "2" or "3 " in the display depending on chosen position.

Using Memory Presets

Press one of the memory buttons and the system will start driving to the preprogrammed memory position. Keep the button pressed until the position is reached.



Display Function



Shows the actual height

Other Functions:**Adjusting Initial Height**

It may be necessary to adjust the displayed height due to different thicknesses of desktops. The control will display 24.5 inches as the default desk height.

Procedure:

- a. Press () and () keys at the same time and keep them pressed for 5 seconds. This allows the initial height to be adjusted. Until the initial height is adjusted, the display will show three minuses(---). Hereafter the display will revert to showing the height.

- b. The height can then be adjusted by either () or () until desired height has been reached. The system will return to normal operation (and give a short blink) after 5 seconds of inactivity on the keys.



ANTI-COLLISION™ FEATURE

NextDesk offers an anti-collision feature that can limit material damages to a desk if a collision with a solid object should occur.

Enabling the anti-collision

To enable the anti-collision function, a dongle must be mounted on one of the two control ports of the control panel on the underside of NextDesk. The function is only active when the dongle is mounted.

If you remove the dongle the anti-collision function is disabled. Inspect NextDesk prior to use to determine if the anti-collision dongle is properly inserted. Do not use NextDesk if the anti-collision dongle has been removed.

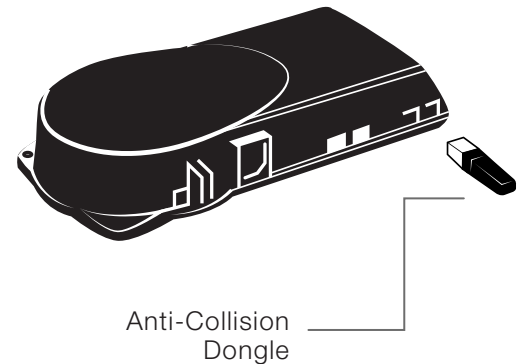

Method of operation

The control box monitors the electric consumption on each lifting column. If the electric consumption on one channel is increased more than a predefined slope, a collision is assumed. All channels are stopped immediately and all desk legs will start to run in the opposite direction (approximately 50 mm). The anti-collision sensitivity is different in upward and downward direction. Upwards the force is approximately 20 kg. Downwards the load will be approximately 40 kg + the load on the desk lifting column (the desk + what is on top of the desk).

Situations where the anti-collision does not work

These situations are:

- If the collision happens during the initialization phase
- If the collision happens within the first 1000 milliseconds or after the control button has been released
- If the collision happens between the floor and the table, and the load on the desk, plus the weight of the legs are lower than 40 kg
- If the collision happens over too long of a time, e.g. if the collision is with a soft object



Maintenance

Clean dust and dirt on the outside of the NextDesk and other components at regular intervals and inspect them for damage and breaks. Inspect the connections, cables, and plugs and check for correct functioning as well as the security of the connection points.



The cleaners and disinfectants must not be highly alkaline or acidic (pH value 6-8).



WARNING! The NextDesk systems do not withstand oil.

Description of the NextDesk

Each NextDesk actuator/lifting column is equipped with a motor, and synchronicity is ensured by means of software that also takes account of an oblique load on the desk. Soft start and stop are also part of this software, which ensures a soft start and stop when adjusting the desk.

Maximum Duty Cycle:

Irrespective of the load, the duty cycle of 10% (6 min./ hour) or maximum 2 min. at continuous use must NOT be exceeded, as this will result in overheating of the motor and control box. Exceeding the duty cycle will result in a dramatic reduction of the life of the system.



Troubleshooting and Repairs:

Error Codes

Below are the possible error codes which may be displayed on the controller

Error Code	Description	Solution
E01	Lifting columns are in an unknown position	Initialize or Reinitialize - Refer to Page 10
E02	Overload in upwards direction has occurred.	Reduce the weight on NextDesk
E03	Overload in downwards direction has occurred.	Remove objects that prevent downward movement
E16	Illegal keys are pressed	Release all buttons & press a valid button or button combination

Repairs:

In order to avoid the risk of malfunction, all NextDesk repairs must be carried out by authorized NextDesk repair centers as special tools and gaskets must be used.



WARNING! If any of the NextDesk products are opened, there will be a risk of subsequent malfunction.



Limited Warranty

SCOPE OF WARRANTY

Next Technologies, Inc. (“NextDesk”) warrants to the original purchaser its new desks (except for components not warranted under “Exclusions”) manufactured by NextDesk to be free from defects in material and workmanship under normal use and service. NextDesk’s obligation under this warranty is limited to the repair or replacement, at NextDesk’s option, of the parts or the products the defects of which are reported to NextDesk within the applicable warranty period and which, upon examination by NextDesk, prove to be defective.

APPLICABLE WARRANTY PERIOD

The applicable warranty period, measured from the date of delivery to the original user, shall be three (3) years for all warranted desks.

EXCLUSIONS

This warranty does not cover and NextDesk shall not be liable for the following:

(1) repairs and replacements because of misuse, abuse, negligence, alteration, accident, freight damage, or tampering; (2) products which are not installed, used, and properly cleaned as required in the NextDesk “Installation” and or “Installation / Operation Manual for this applicable product. (3) products considered to be of a consumable nature; (4) Shipping to or from repair center; (5) accessories or parts not manufactured by NextDesk; (6) charges by anyone for adjustments, repairs, replacement parts, installation, or other work performed upon or in connection with such products which is not expressly authorized in writing in advance by NextDesk.



EXCLUSIVE REMEDY

NextDesk's only obligation under this warranty is the repair or replacement of defective parts. NextDesk shall not be liable for any direct, special, indirect, incidental, exemplary, or consequential damages or delay, including, but not limited to, damages for loss of profits or loss of use.

NO AUTHORIZATION

No person or firm is authorized to create for NextDesk any other obligation or liability in connection with the products.

THIS WARRANTY IS NEXTDESK'S ONLY WARRANTY AND IS IN LIEU OF ALL OTHER WARRANTIES, EXPRESS OR IMPLIED. NEXTDESK MAKES NO IMPLIED WARRANTIES OF ANY KIND INCLUDING ANY WARRANTIES OF MERCHANTABILITY OR FITNESS FOR ANY PARTICULAR PURPOSE. THIS WARRANTY IS LIMITED TO THE REPAIR OR REPLACEMENT OF DEFECTIVE PARTS.

